

RELCO[®] Cheesemaking Equipment

Leading Technology for Desirable Cheese Products

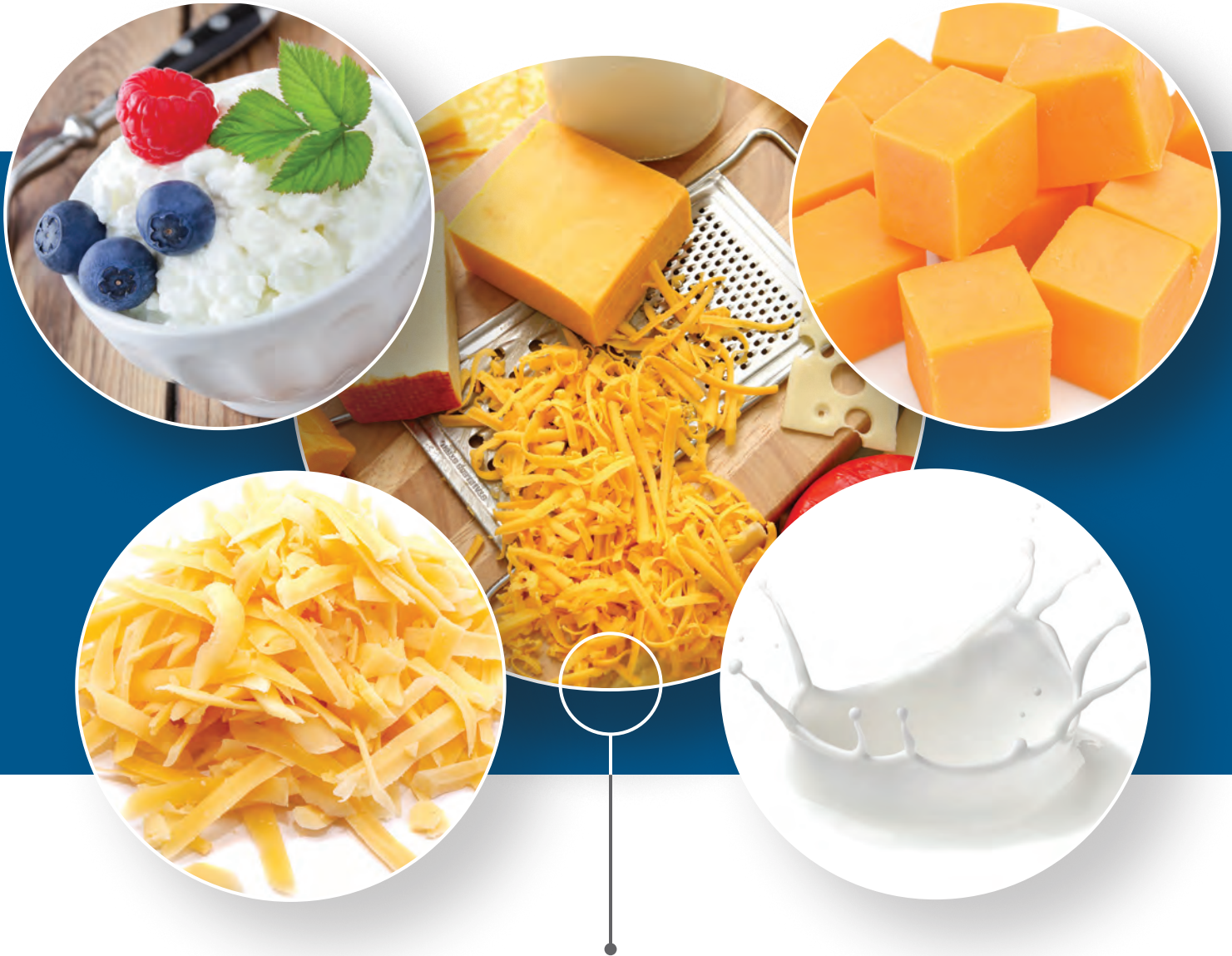

RELCO[®]
A Kovalus Company

Leading Separation Technology

KOVALUS SEPARATION SOLUTIONS™ (KSS) is transforming the landscape of separations by leveraging a synergistic approach using technologies such as membrane filtration, ion exchange, evaporation, and drying. Our solutions are tailored to improving product quality, increasing process efficiency, and driving down costs in dairy, food, beverage, life science, and industrial markets around the world.

We are pleased to offer RELCO® cheesemaking equipment to our customers, a line of technology trusted by top cheesemakers around the world. Our equipment is constructed with sanitary materials to ensure compliant operation within the dairy industry. We offer a variety of optional features and a high degree of customization to meet our customers' unique processing needs. Our team of engineers partner with cheesemakers to ensure a reliable, high-performance process to achieve the most desired cheese products.

Equipment

- Cheese vats
- Cheese belt
- Curd table
- Blockformer
- Coagulation detector
- Valves

Types of Cheeses

- Cheddar
- Colby
- Gouda
- Cottage cheese
- Edam
- Jack-styles (including peppers)
- Havarti
- Asiago
- Parmesan
- Mozzarella
- And more



Innovative and Collaborative Approach

Complete Process Solutions

KSS is a complete process solutions provider in the dairy and food industries, offering a suite of complementary separation technologies for a range of in-process applications and water and wastewater treatment. Our integrated, start-to-finish capabilities position KSS to be a preferred partner to a variety of manufacturers in these key industries, eliminating the need for multiple vendors. Aside from our leading technologies, customers benefit from long-lasting relationships with our engineering and field service teams for superior aftermarket services and support to maintain and optimize on their high-performing operations during the entire equipment lifetime.



Collaborative Innovation

We take a collaborative approach with our customers, combining our deep applications knowledge with their unique process expertise to develop the most transformative and value-added solutions. Through this approach and our wide selection of separation technologies, KSS is best positioned to offer customers a complete solution without the need to rely on multiple vendors.

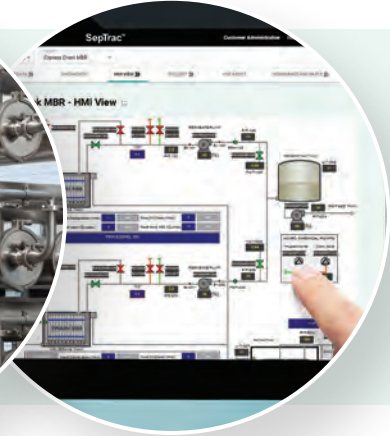

EARLY-STAGE DEVELOPMENT

- Understand challenge & identify desired outcomes
- Evaluation of separation properties & bench testing
- Access to Process and R&D experts

FIELD TESTING

- Pilot testing
- Process optimization
- Full scale costing and design recommendation

FULL-SCALE EXECUTION

- Project management & execution of capital projects
- Construction and installation
- Commissioning and operator training

LONG-TERM SUPPORT

- Complete after-sales services
- System troubleshooting
- Performance optimization through remote digital monitoring program

Cheesemaking Equipment

Cheese Belt

We work closely with a partner to design and develop a hygienic, robust, and versatile cheese belt. Features such as weir design, curd height, retention time, and style/number of stirrers are highly customizable to produce a variety of cheese types. The cheese belt is available in four different widths to allow capacities of 2,000 – 33,000 lbs/hour (900 – 15,000 kg/hr) in a fully enclosed and controlled environment. Solids retention in the cheese curds is maximized through an adjustable “wedge wire screen” de-wheying system, and tempered water addition optimizes lactose removal. Our belt is fitted with vertical peg stirring for effective curd agitation and solids retention and a “herring bone” belt support design ensures a longer belt life and enhanced performance. CIP turnaround is optimized through a strategic shut-off device between the first draining and matting belt and the second matting belt.



SVC Cottage Cheese Vat

The SVC Cottage Cheese Vat is 3A certified machine, designed specifically for cottage cheese and fresh cheese production, minimizing curd damage, and providing high product yields. This vat accommodates capacities of up to 6,000 gallons (about 22,700 liters) and is constructed with stainless steel inside and out to provide a strong liner and jacket. From the sealed, stainless bearings on the carriage wheels to the white epoxy painted motors and gear boxes, this vat features an optimized design to reduce maintenance, simplify cleaning, and prolong equipment life.



With the Verti-Stir Sanitary Agitation System, curd is continuously kept in suspension through a gentle elliptical motion. The SVC vat features advanced automation and control technology, including encoder technology on the travel motor for accurate carriage positioning, dual operator pendants with sealed-touch buttons for sanitary operation above the product zone, and on-board PLC & HMI for local control of the Verti-Stir Sanitation Agitation System. RELCO® technology is highly customizable, and the SVC vat can include the following optional features:

- Internal spray heating and cooling system (jet cooker)
- Whey recirculation system
- Tubular heat exchanger
- Milk stirring paddles
- Mechanical and cross-cut knives
- Carriage cover
- Stainless motors
- Curd pusher
- Creaming paddles
- Unloading blades
- Various sized stir arms

Cheesemaking Equipment

OO Style Vat

Our OO Style Vat for cheesemaking is constructed with sanitary materials to ensure compliant operation. The exterior finish and exterior weld seams are bordered and bead blasted, and product-contacting interior weld seams are ground and polished to a 150-grit sanitary finish. The vat features a closed jacket heating system. We offer vat sizes to accommodate capacities of 25,000 – 30,000 lbs (11,000 – 14,000 kg) as well as 35,000 – 40,000 lbs (16,000 – 18,000 kg).

HORIZON II Cheese Vat

The HORIZON® II Cheese Vat features an enclosed, horizontal single-shaft design for increased yields, uniform curd size, consistent moistures, and low whey fats. The HORIZON II vat easily handles high solids cheese production. The equipment is manufactured with sanitary materials to meet 3A standards and USDA guidelines for dairy equipment. The design features a convenient seal replacement without the need to remove the gear box, stainless steel knives, a manway option on either end, heavy duty external bearings, a multi-port rennet inject header, and an optional coagulation detection and a steam or hot water heating system. Customized installation is available to meet unique space and production requirements.

OptiSet 4.1 Coagulation Detection System

The OptiSet 4.1 Coagulation Detection System monitors the curd coagulation process within the vat to identify the exact instance of coagulation. Based on input from the cheesemaker, coagulum cutting is initiated when the optimum firmness is achieved. The OptiSet system also serves as a powerful diagnostic tool, helping cheesemakers understand the effect of upstream processes and conditions such as set temperature, changes in milk chemistry, and type or amount of starter/rennet on coagulation. The software and hardware never require calibration and recipes can be created and saved in the program for a variety of cheeses. Data is displayed for each OptiSet probe and is stored in a daily data log for review and retrieval. The system works to reduce cost, maximize yields, and provide better consistency from vat to vat.



OO Style Vat



HORIZON II Cheese Vat



OptiSet 4.1 Coagulation
Detection System

Cheesemaking Equipment

TRU-FINISH Curd Table

The RELCO® TRU-FINISH® Curd Table is designed with the customer in mind to provide fast, efficient, and sanitary separation of curd and whey to produce a variety of cheeses. This cheese finishing table also facilitates the uniform mixing of salt and condiments into the curd bed. It comes available with permanent drain screens and drain trough, or traditional removable drain screens. Our patent-pending forker shoes and rugged agitator design guarantee thorough mixing of the product. Tools and accessories are designed to be mounted and changed with a minimal amount of effort. Cheese product can be discharged to a RELCO Curd Unloader for either air conveying, vacuum conveying, or inclined auguring to downstream processes. The table is offered as three standard models that are highly customizable with a number of optional features:

- **TRU-FINISH curd table:** Features our premium rack and pinion drive, has an integrated drain screen, and is CIP enabled.
- **TRU-FINISH Classic curd table:** A chain-driven unit with an integrated drain screen and CIP.
- **TRU-FINISH Classic Lite curd table:** Our basic model, featuring a chain-driven unit with removable drain screens.



Curd Unloader

The RELCO Curd Unloader provides reliable transfer of salted curd to block formers, 640 lb hoop filling, 500 lb barrel filling, or manual hooping of a variety of cheeses. It is designed for safe operation, high throughput, and guaranteed performance. Available in multiple widths to accommodate a variety of curd draining table dimensions, the unit can be configured for air (blowing or vacuum) or mechanical (auger) transfer to downstream processes. Our curd unloader handles a significant amount of product while the curd finishing table retrieves more cheese, efficiently and gently moving cheese from the sides of the hopper to the center pick-up points. Tines are attached to the ribbon auger shaft to assist curd from bridging. Curd exits the unloader via vacuum ports or the optional Star Valve sized to meet specific processing needs. Optional mounting equipment is available including casters, overhead rail systems, and an additional optional curd transport system to eliminate hoses on the floor.



Cheesemaking Equipment

Star Valve

The RELCO® Star Valve is a rotary valve designed specifically for the pneumatic transport and differential pressure air lock applications for cheese curd and similar dairy products. Available in two standard sizes, the Star Valve is designed to meet dairy equipment standards featuring removable vanes and a variety of production and cleaning configurations.

The 10" and 12" valves transport up to 14,000 and 24,000 lbs/hour (6,000 and 11,000 kg/hr), respectively.

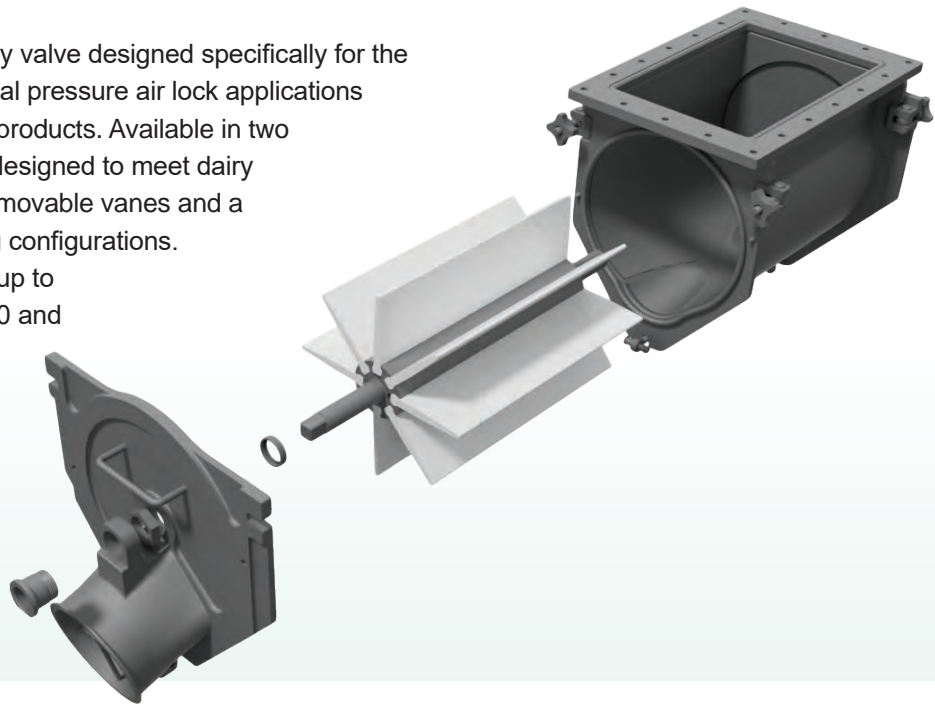

TRU-BLOCK Blockformer

The latest in block forming technology, our TRU-BLOCK® Blockformer features a high-quality, heavy-duty design that meets USDA guidelines. It is available in three standard sizes:

- 18' Standard Tower (processes up to 2,000 lb/hour or about 907 kg/hour)
- 22' Extended Tower (processes up to 2,500 lb/hour or about 1,134 kg/hour)
- 32' High Capacity Tower (processes up to 3,500 lb/hour or about 1,588 kg/hour)

Our patent-pending tower screen features a dense grid of perforations and formed standoffs. The unit uses a ball screw actuator with an absolute encoder and built-in break to ensure accurate platform height control, and is designed for fast and easy inspection. There is a minimal gap between the screen and tower to allow excellent curd fusion into blocks for a variety of cheeses. The TRU-BLOCK unit includes easy cleaning and maintenance and full automation capabilities to integrate with existing processes.

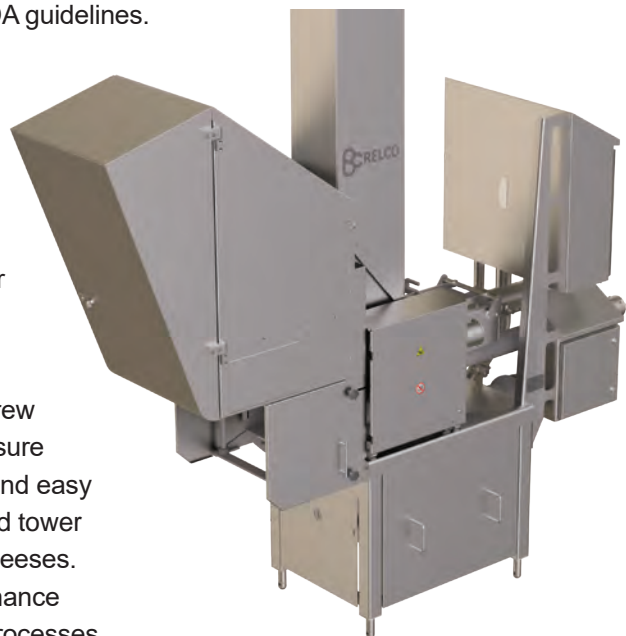



KOVALUS SEPARATION SOLUTIONS

KOVALUS SEPARATION SOLUTIONS™ (KSS) is a global leader in separation technologies.

With best-in-class domain expertise, technologies and systems, KSS is uniquely positioned to help customers purify and recover valuable process streams and achieve sustainability goals across food and beverage, life science, and general industrial markets.

Services & Support

After-Sales Services & Maintenance Programs • SepTrac™ Smart System



www.kovalus.com • getinfo@kss-sep.com
www.relco.net • relco_sales@kss-sep.com

KOVALUS
Separation Solutions™

RELCO
A Kovalus Company

For complete contact information and listing of our global locations, visit www.kovalus.com
©2023 KOVALUS SEPARATION SOLUTIONS, LLC. All rights reserved worldwide.
For related patent and trademark information, visit www.kovalus.com/legal. 10/23